

STEREO TURNTABLE

PL-115D

OPERATING INSTRUCTIONS

KLT
KCT
KUT



Walnut grained vinyl cabinet

 **PIONEER**

WARNING: TO PREVENT FIRE OR SHOCK HAZARD,
DO NOT EXPOSE THIS APPLIANCE TO RAIN OR
MOISTURE.

The PL-115D is a high precision belt drive turntable designed for incorporation into a component type stereo music system. It is recommended that you read these Operating Instructions completely before using the turntable.

The PL-115D is prelubricated at the factory, but the oil may have dried up during shipment, so before use apply a few drops of the accessory oil as described on page 10.

CONTENTS

PL-115D Features	2
Attaching the Cartridge	3
Assembly Steps	4
Component Locations	5
Tonearm Adjustments	6
Stereo Amplifier Connections	7
Dust Cover	7
Panel Facilities	8
Operation	9
Care of Your Turntable	10
Conditions Frequently Mistaken for Malfunction	11
Specifications	12

PL-115D FEATURES

Precision Belt Drive with 4-pole Synchronous Motor

Stable rotation of the 30cm diecast aluminum alloy platter is maintained by the carefully engineered 4-pole synchronous motor and belt drive system. The smooth running of the motor is unaffected by fluctuations in line voltage and load, while even the slightest vibrations from the motor are absorbed by the polyurethane belt. High performance is exemplified by the 0.07% (WRMS) wow and flutter, and 50dB (JIS) signal to noise ratio.

Speed Detector Type Auto Return Mechanism

Faulty auto return is avoided by employing a speed detector system in the mechanism to assure perfect operation at the end of the record. By pressing the RETURN button the auto return mechanism can also be used to interrupt a record during play, at which time the tonearm is raised and returned to the arm rest without risk of damage to the record.

High Sensitivity S-shaped Tonearm

The tonearm gimbal incorporates high precision angular contact bearings, whose low vibration and friction ensure high sensitivity together with long term reliability. Anti-skating and lateral balance controls are included for optimum performance with high compliance cartridges and light tracking forces, and the direct readout of the tracking force is especially convenient when replacing the cartridge.

Sophisticated Cabinet Styling

The baseplate is made from mineral solid, a new high density material which combines excellent acoustic absorption properties to prevent resonance with high strength and attractive finish. In addition the elegant wood grain finish of the cabinet ideally matches the high quality engineering of the PL-115D.

Numerous Additional Features

A host of additional features enhance the convenience and performance of the PL-115D. Among these are a lightweight, high rigidity aluminum headshell, low capacitance output cord, and an oil-damped tonearm elevation mechanism to protect valuable records and stylus. The interior of the cabinet is lined with aluminum foil to screen out external electrical noise which is often picked up from other household appliances, while motor and external vibrations are also isolated by the double suspension design.

ATTACHING THE CARTRIDGE

Moving magnet (MM), moving coil (MC) and induced magnet (IM) are the main cartridge types. Although all of these can be used with the PL-115D, select cartridges with weights between 4—10 grams. Refer to the cartridge operating instructions for connection and handling. Since the tonearm of the PL-115D is a universal type, your optional cartridge with standard type headshell can be attached with no problem. Install the cartridge to the headshell according to the following steps.

1. When attaching cartridge to the accessory headshell, use the headshell, screwdriver, overhang gauge, screws, nuts and washers supplied in the accessory box (Fig. 4).
2. Connect headshell lead wires to the cartridge. Observe lead wire color coding as follows.

White	L	(left channel)
Blue	LG	(left channel ground)
Red	R	(right channel)
Green	RG	(right channel ground)
3. Fit cartridge to headshell (Fig. 1), but do not tighten the mounting screws yet.
4. Set the headshell into the accessory overhang gauge as shown in Fig. 2. Adjust the cartridge position so that the stylus tip is aligned with the gauge line. Finally, tighten the cartridge mounting screws.
5. Install headshell on tonearm according to Fig. 8 on next page.
If your cartridge weighs over 8.5g, insert the sub weight into the end of the tonearm shaft. Refer to Fig. 3.

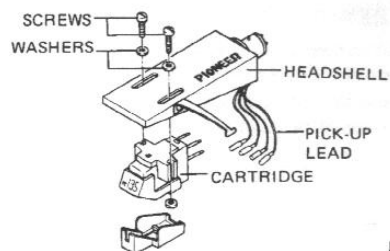

Fig. 1

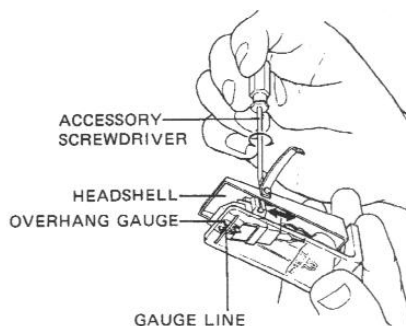

Fig. 2

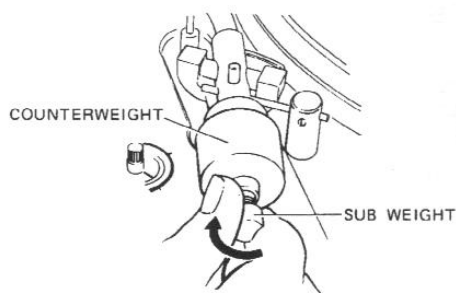

Fig. 3

ACCESSORIES

The accessory box contains the following parts.

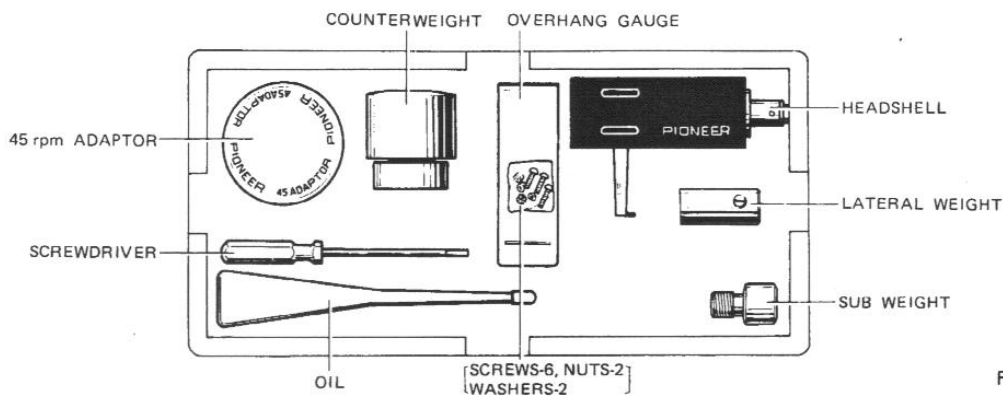

Fig. 4

ASSEMBLY STEPS

1. REMOVE TONEARM PACKING

The tonearm is protected by styrofoam cushioning material during shipment. Peel off the tape and while taking care not to exert unnecessary force on the tonearm, remove the packing material (Fig. 5).

2. TAKE OUT CLAMP SCREW

To protect from possible damage in transit, the chassis is secured to the base plate with the 5 screws (Fig. 6). These must be removed before assembling the turntable. The chassis will then float on its vibration-absorbing spring suspension.

3. INSTALL TURNTABLE PLATTER

Use the two finger holes in the platter to lift it and carefully place it onto the center shaft (Fig. 11).

4. MOUNT THE BELT ON THE MOTOR PULLEY

Set the speed select lever to 33 position. Pulling the ribbon attached to the drive belt, pass the belt through the belt guide and around the smaller diameter (the upper portion) of the motor pulley (Fig. 7).

After the belt has been properly positioned on the motor pulley, remove the ribbon and place the rubber mat and decorative ring (see Fig. 11).

5. INSTALL HEADSHELL

Insert the headshell into the tonearm sleeve and lock it in place by turning the locking collar (Fig. 8).

6. MOUNT COUNTERWEIGHT

Fit the counterweight onto the rear end of the tonearm and turn it 2 or 3 times in the direction of the arrow (Fig. 9).

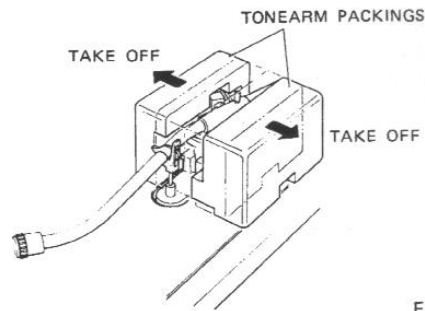

Fig. 5

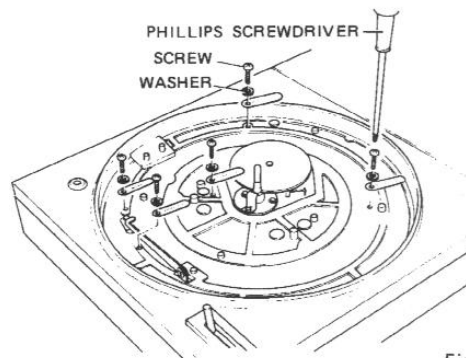

Fig. 6

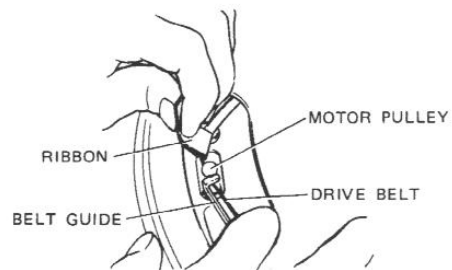

Fig. 7

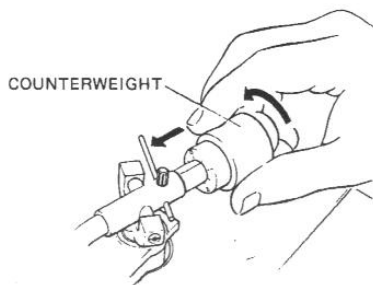

Fig. 9

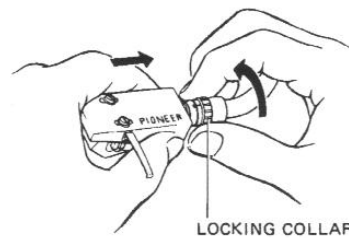

Fig. 8

7. ATTACH LATERAL WEIGHT

Use the accessory screwdriver to fix the lateral weight on its bar and adjust for 18–23mm spacing between the lateral weight and tonearm (Fig. 10). Readjustment is not required, even after replacing the cartridge.

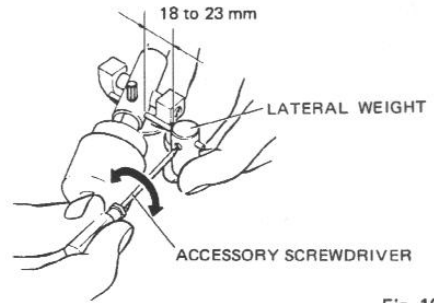

Fig. 10

COMPONENT LOCATIONS

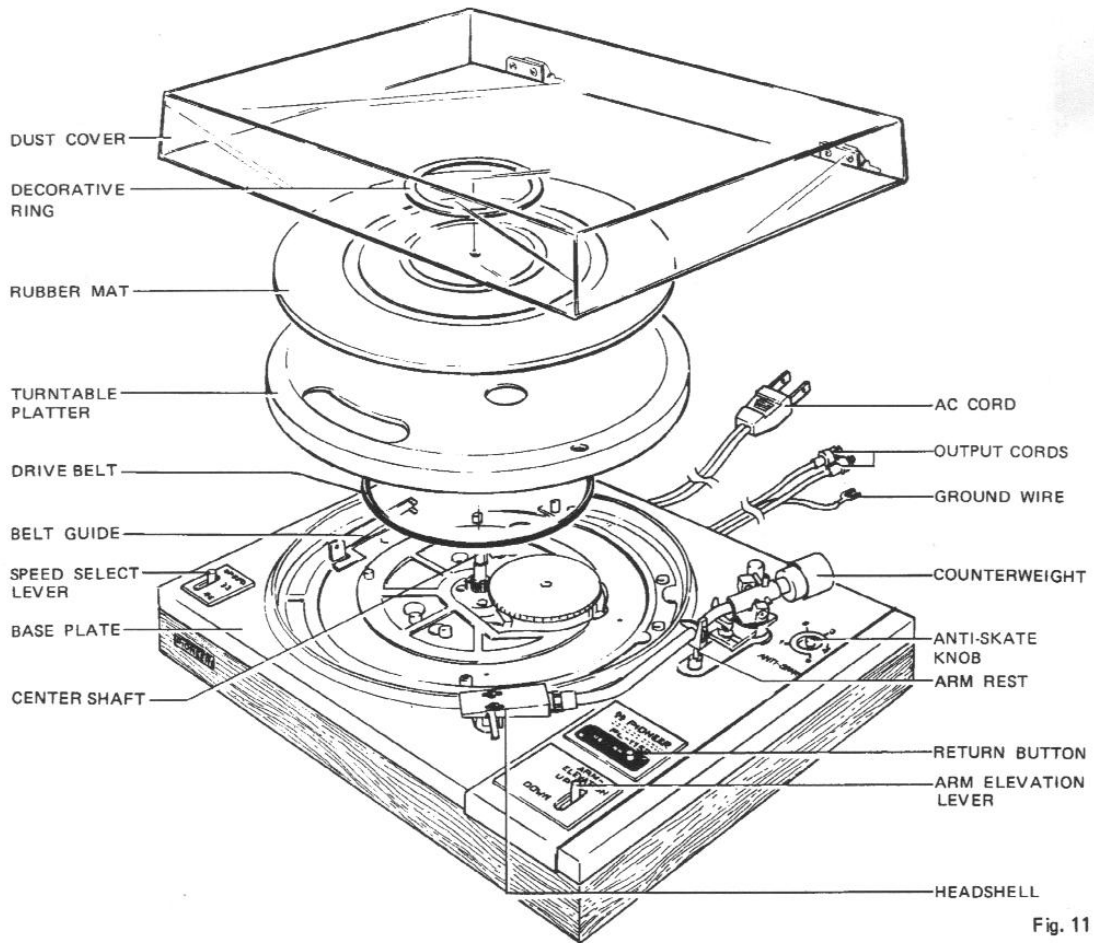
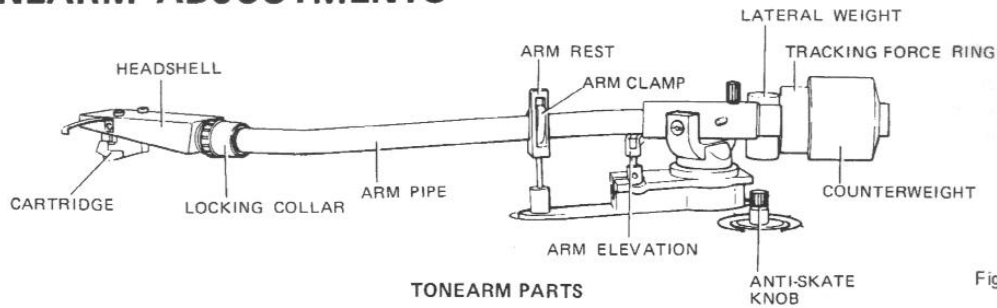

Fig. 11

ONEARM ADJUSTMENTS



TONEARM PARTS

Fig. 12

After correctly assembling the tonearm, perform the following adjustments. Do not connect the AC cord to the mains outlet until adjustments have been completed.

HORIZONTAL BALANCE

1. Set ANTI-SKATE knob to 0 (Figs. 12 and 14).
2. Uncover the stylus.
3. Set the arm elevation lever to DOWN.
4. Release the arm clamp and disengage the tonearm from the arm rest. Since the tonearm moves freely at this time, take care not to damage the stylus.
5. Turn the counterweight and adjust so that the tonearm becomes level with the platter, without slanting either toward the headshell or counterweight. Figs. 13-A and 13-B show the tonearm in unbalanced conditions.

NOTE:

If the cartridge is too heavy to adjust by this means, attach the sub weight according to Fig. 3 on page 3.

6. Return the tonearm to the arm rest and engage the clamp.
7. Since the tonearm is balanced, the tracking force is zero, so turn the tracking force ring at the front of the counterweight (taking care not to disturb the counterweight) to align the 0 with the reference line (Fig. 14).

TRACKING FORCE

Turn the counterweight and align the indication on the tracking force ring which corresponds to the recommended tracking force of the employed cartridge with the reference line (Fig. 15). The ring is divided into 0.5 gram divisions and 1 rotation is equivalent to 4 grams tracking force.

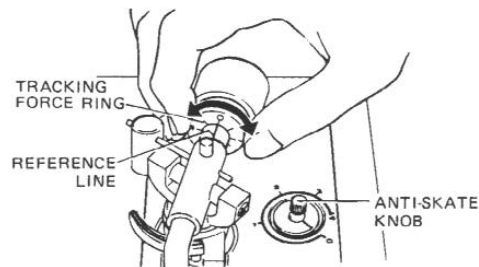
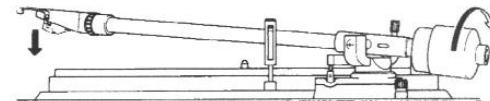
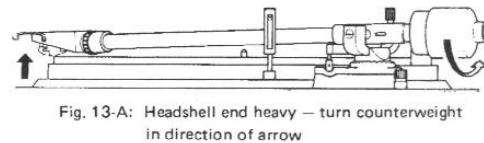
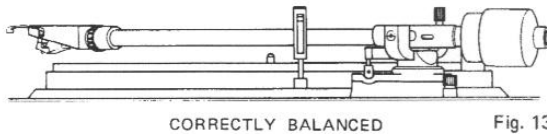

Fig. 14

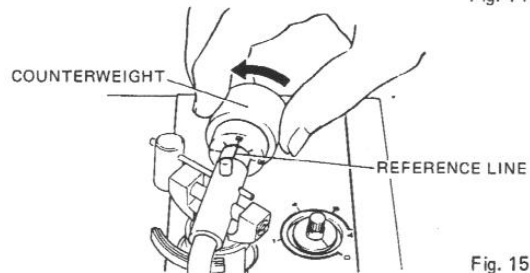

Fig. 15

ANTI-SKATING

Set the ANTI-SKATE knob to the same value as the tracking force of the employed cartridge. For example, if the tracking force is 2 grams, set this knob to 2 (Fig. 16).

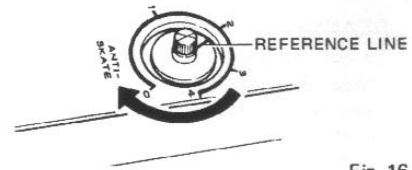

Fig. 16

STEREO AMPLIFIER CONNECTIONS

The phono inputs of the amplifier to which the turntable should be connected must be chosen in accordance with type of phono cartridge to be used.

- With moving magnet or induced magnet type cartridge:
Connect to the PHONO MAG inputs of the amplifier.
- With low-output moving coil type cartridge:
Connect to the PHONO MC inputs. If these are not provided on your amplifier, a step-up transformer will be required.

NOTE:
Refer to the cartridge instruction manual for further detail.

In either case, connect the red output plug from the turntable to the amplifier's right channel input and the white plug to the left channel input. The third black wire (the ground wire) with the split plug can be connected to the GROUND terminal of your amplifier (Fig. 17). Do not forget to make this connection, because it is vital for avoiding hum and noise.

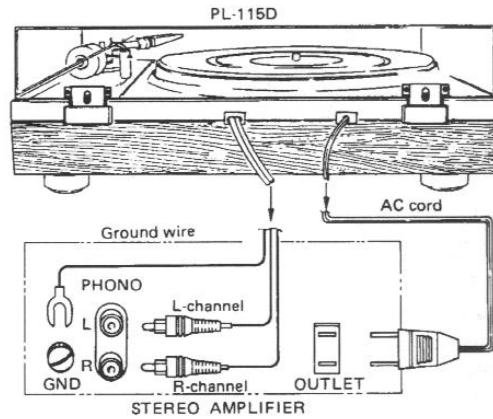

Fig. 17

DUST COVER

It is convenient to install the dust cover from the rear of the turntable as shown in Fig. 18. Hold the cover at the bottom and insert its hinges into the sockets of the turntable base. To remove the dust cover, again grasp it as shown in Fig. 18 and pull it straight upward.

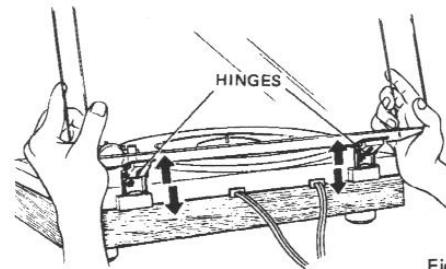

Fig. 18

INSTALLATION HINTS

Pay attention to the following points when selecting a location for the PL-115D.

- The place must be well-ventilated and free from humidity and dust.
- Avoid exposure to direct sunlight or other sources of heat.
- The turntable should be placed as far from the speaker system as possible, and not too close to the power transformer of the amplifier.
- Select a surface that is firm and level.

PANEL FACILITIES

HEADSHELL STAND

A spare headshell can be stored in this stand. Align the headshell pins with the stand grooves and insert. Observe that the headshell length is not greater than the height of the dust cover. This stand can also be used for storing the 45rpm adaptor.

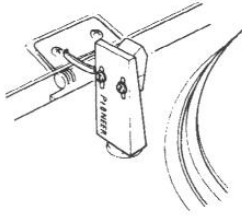

SPEED SELECT LEVER

Either of the two speeds, 33-1/3rpm or 45rpm, can be selected by this lever. Only change the position while the turntable is rotating.

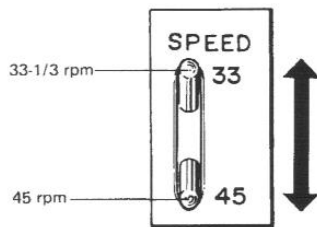

45RPM ADAPTOR

A 45rpm record adaptor is supplied in the accessory box, which permits 45rpm EP records with large center holes to be played.



RETURN BUTTON

To stop playback before the end of a record, press this button; the tonearm returns automatically to the arm rest then the power is switched off.



RETURN
BUTTON

ARM ELEVATION LEVER

Setting this lever to UP raises the tonearm, while setting it to DOWN lowers the tonearm gently onto the record. This device is convenient for cueing any position on the record without fear of scratching the record surface.

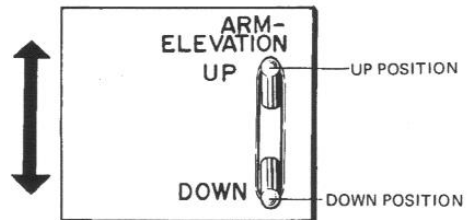

OPERATION

ARM ELEVATION

Arm elevation may require adjustment according to cartridge height. If necessary, use the accessory screwdriver to loosen the setscrew and adjust (see figure).

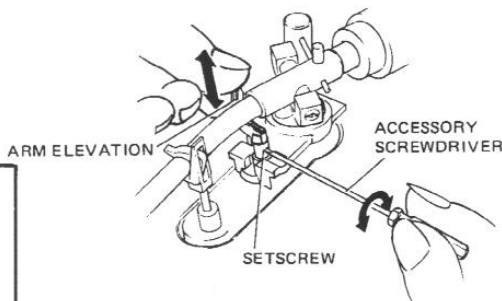

ARM REST

The arm rest supports the tonearm, which should be secured by the arm clamp when not in use. Before raising the tonearm, be sure to release the clamp.

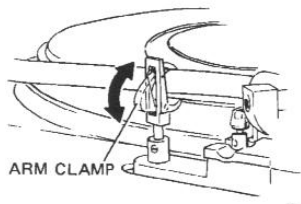

1. Place the record to be played on the turntable platter.
2. Remove the stylus cover and disengage the arm clamp.
3. After setting the ARM ELEVATION lever to UP, move the tonearm from the arm rest. (The turntable platter will begin to rotate.)
4. Set the SPEED select lever to the correct speed according to the record to be played.
5. Position the tonearm above the desired portion of the record by hand.
6. Move the ARM ELEVATION lever to DOWN. The stylus will be gently lowered onto the record.
7. Adjust the volume and tone controls of the stereo amplifier as desired.
8. When the record is finished, the tonearm returns to the arm rest automatically and the power is cut off.

It is advisable to replace the stylus cover for protection whenever the turntable is not in use.

NOTE:

Before playing the next record, be sure to re-set the ARM ELEVATION lever to the UP position to avoid damage.

- If you wish to stop play in the middle, simply push the RETURN button (The tonearm will return to the arm rest, then the power will be switched off).

To Take Full Advantage of the Arm Elevation Lever

The ARM ELEVATION lever is particularly convenient when you wish to choose a particular track from an LP record.

- If you move the tonearm with the ARM ELEVATION lever set to DOWN, take care not to damage the stylus point.

OPERATING PRECAUTIONS

- Keep stylus and records clean. Use a stylus brush to clean the stylus and a good quality record cleaner to clean the records each time before and after playing.
- Avoid exerting unnecessary force on the tonearm. When changing headshells, set the tonearm in the arm rest and engage the clamp.
- Take care not to impart vibration to the turntable while a record is playing. Record and stylus can be damaged.
- Never touch the SPEED select lever if the turntable is stationary. The speed can be changed only while the turntable is rotating.
- Never obstruct the turntable by hand while it is rotating. This may cause damage.

CARE OF YOUR TURNTABLE

CLEANING CABINET

Use a polishing cloth or a soft dry cloth to clean dust from the cabinet and dust cover. Do not use household waxes, solvents or sprays on or near the turntable as they can mar the finish.

LUBRICATION

Mechanical noise or wow and flutter usually result from a lack of lubricant in the rotating parts. Lubricate the following point at least once every two months for normal use, and two to three times if the turntable is used very frequently.

Before applying oil to the turntable, remove the turntable platter as follows:

1. Remove the dust cover as described in "DUST COVER" on page 7.
2. Return the tonearm to the arm rest and clamp it, then protect the stylus tip with the stylus cover.
3. Remove the drive belt from the motor pulley with your fingers (Refer to Fig. 7 on page 4).
4. Lift the turntable platter straight up by inserting fingers and thumb into the two openings (Fig. 19).

If the platter does not come away easily, try jerking it, but take care not to damage any part of the turntable.

5. Apply one or two drops of the accessory oil to the lubricating hole (Fig. 20), being careful not to get oil on parts such as the motor pulley, belt, or inner rim.

NOTE:

If oil should adhere to the motor pulley, inner rim, or drive belt, wipe it off with a cloth moistened with pure alcohol.

Caution: Never use other solvents.

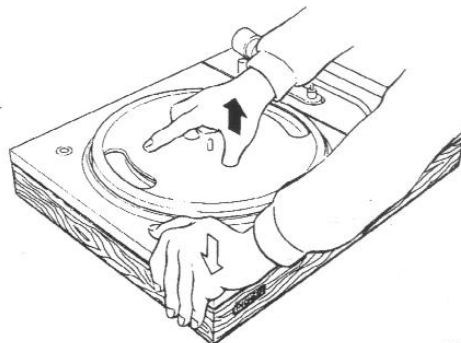

Fig. 19

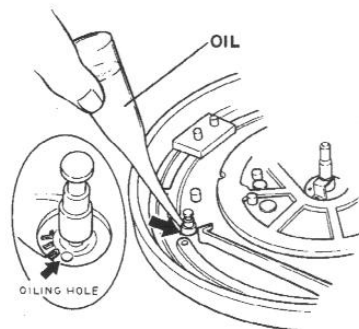

Fig. 20

CONDITIONS FREQUENTLY MISTAKEN FOR MALFUNCTION

If no sound is obtained from the speakers after assembling this turntable, please check the connections and operation of the other components as follows: (a) internal connection of headshell (e.g. terminal tips, lead wire ..) (b) attachment of locking sleeve (c) output cord connections (d) speaker wire connections (e) amplifier settings (e.g. VOLUME, FUNCTION, TAPE MONITOR, POWER switch ..)

SYMPTOM	SUSPECTED SOURCES OF NOISE	DIAGNOSIS AND REMEDY
Turntable does not rotate	(a) AC cord is not connected to AC outlet (b) Drive belt is disconnected or loose	Check (a) or (b) and correct the condition
Incorrect turntable speed	(a) Speed select lever is incorrectly set (b) Drive belt is incorrectly fitted (c) Motor pulley and belt are dirty (d) The frequency of your power supply does not suit the PL-115D	Correct the conditions stated in (a) and (b) Wipe the motor pulley and belt clean with a soft cloth dampened with pure alcohol Contact to Pioneer Authorized Service Station
Hum or buzz	(a) Poor connection of shielded wire (b) Jack connection is loose (c) Line cord of fluorescent lamp passes near the shielded wire (d) Poor grounding (e) Shielded wire is running near the power transformer of the amplifier (f) Ham transmitting station or TV transmitting station is near your house	Correct the conditions stated in (a), (b), (c), (d) or (e) (Reversing the AC connections may occasionally eliminate hum) In the case of (f), report it to an official authority
Poor tone quality, noise, unclear treble	(a) Stylus is worn (b) Record is worn (c) Dust adhering to stylus (d) Stylus is improperly mounted (e) Stylus pressure is not correct (f) The TREBLE level of the amplifier is too high	Check (a) through (e) and correct the condition Lower the TREBLE level
Howling	(a) Distance between the turntable and the speakers is too short (b) The turntable or speakers supports are unstable (c) Clamping screws are not removed yet	Increase the distance or rearrange the installation of the unit and speakers (Installing the turntable on a firm, solid stand may alleviate this problem) Do not enhance the BASS sound level excessively Take out the clamping screws according to Fig. 6 on page 4

SPECIFICATIONS

MOTOR AND TURNTABLE

Motor	4-pole synchronous
Turntable drive	Belt-driven
Speed	Two speeds: 33-1/3rpm, 45rpm
Wow and flutter	0.07% (WRMS) or less
S/N	50dB (JIS) or more (using Pioneer cartridge model PC-135)
Turntable platter	30cm diam. aluminum alloy
Moment of inertia	135kg-cm ² (including rubber mat)

TONEARM

Tonearm type	Static-balance, S-shaped, pipe arm
Effective arm length	221mm
Tracking error	+3° ~ -1°
Overhang	15.5mm
Usable cartridge weight	4g (min.) ~ 10g (max.)

(For cartridge weighs over 8.5g, attach the sub weight)

SUBFUNCTIONS

- Automatic return tonearm system
- Anti-skating force control
- Plug-in type headshell
- Oil-damped arm elevator
- Hinges (Free-adjustable)
- Lateral balancer

MISCELLANEOUS

Power requirements	AC 120V, 60Hz
Power consumption	10W
Dimensions	440(W) x 362(D) x 159(H) mm 17-5/16(W) x 14-1/4(D) x 6-1/4(H) in.
Weight	6kg, 13 lb 3 oz.

ACCESSORIES

Headshell	1
Accessory oil	1
Overhang gauge	1
45rpm adaptor	1
Screwdriver	1
Sub weight	1
Cartridge mounting screws	6
Cartridge mounting nuts	2
Cartridge mounting washers	2
Operating instructions	1

NOTE:

Specifications and design subject to possible modification without notice due to improvements.

PIONEER ELECTRONIC CORPORATION

4-1, Meguro 1-Chome, Meguro-ku, Tokyo 153, Japan

U.S. PIONEER ELECTRONICS CORPORATION

75 Oxford Drive, Moonachie, New Jersey 07074, U.S.A.

PIONEER ELECTRONIC (EUROPE) N.V.

Luithagensteenweg no. 9, 2030 Antwerp, Belgium

PIONEER ELECTRONICS AUSTRALIA PTY. LTD.

178-184 Boundary Road, Braeside, Victoria 3195, Australia

Printed in Japan